

Typical Features

- ◆ Wide input voltage range 85-305VAC/120-430VDC
- ◆ No load power consumption $\leq 0.2W@220VAC$
- ◆ Efficiency up to 82% (Typ.)
- ◆ Operating temperature from $-40^{\circ}C$ to $+75^{\circ}C$
- ◆ Switching frequency 65KHz
- ◆ Short circuit, over current & over temp. protections
- ◆ Isolation voltage 4000VAC
- ◆ Altitude during operation 4000m Max
- ◆ Complies with IEC/UL/EN 62368-1 standards.
- ◆ RoHS Compliant.
- ◆ PCB DIP Mounting



Application Field

The FA5-220SXXY2N4 series from Aipupower is a compact, high-efficiency power module. It features a universal input voltage range (accepting both AC and DC inputs), low ripple, low temperature rise, low power consumption, high reliability, robust safety isolation, and excellent EMC performance. Its EMC and safety specifications comply with international EN55032 and IEC/EN61000 standards. This series is widely used in electric power systems, industrial applications, instrumentation, and smart homes. For operations in harsh EMC environments, please refer to our recommended application circuits.

Typical Product List

Certificate	Part No.	Input Voltage Range		Output Specification			Max. Capacitive Load @220VAC	Ripple & Noise 20MHz (Max)	Efficiency @full load, 220VAC (Typ.)
		Nominal	Range	Power	Voltage	Current			
		(VAC)	(VAC)	P (W)	Vo(VDC)	Io (mA)			
-	FA5-220S3V3Y2N4	220	85-305	4.1	3.3	1250	5000	100 (Ext. Circ. Req.)	73
-	FA5-220S05Y2N4				5	1000			
-	FA5-220S12Y2N4			5	12	416	4000	150	82
-	*FA5-220S15Y2N4				15	333	3000	150	83
-	*FA5-220S24Y2N4				24	208	100	200	84

Note 1: Typical output efficiency is measured after 30 minutes of operation at full load (burn-in).

Note 2: The tolerance for typical full-load efficiency (% , Typ.) is $\pm 2\%$. Efficiency is calculated as total output power divided by the module's input power.

Note 3: Due to space constraints, this is only a partial product list. For models not listed, please contact our sales department.

Note 4: Models FA5-220S3V3Y2N4 and FA5-220S05Y2N4 require an external circuit to reduce ripple. Please refer to Figure 2 for specific external component parameters.

Input Specifications					
Item	Test Condition	Min.	Typ.	Max.	Unit
Input voltage range	AC Input	85	220	305	VAC
	DC Input	120	310	430	VDC
Input frequency	-	47	50	63	Hz
Input current	Input 115VAC	-	-	0.20	A
	Input 220VAC	-	-	0.10	
Surge current	Input 115VAC	-	-	16	A
	Input 220VAC	-	-	30	
Standby power consumption	Input 115VAC	-	-	0.2	W
	Input 220VAC	-	-		
Leakage current	-	0.5mA TYP/230VAC/50Hz			
Hot-plug	-	Not Supported			
External fuse Recommended	-	2A/300VAC Slow--blow fuse			
Remote Control Pin (Ctrl)	-	No Remote Control (CNT)			

Output Specifications						
Item	Test Condition	Min.	Typ.	Max.	Unit	
Output voltage accuracy	Full input voltage range, any load	Vo=3.3V	-	±2.0	±4.0	%
		Others	-	±2.0	±3.0	%
Line regulation	Rated Load	Vo	-	-	±0.5	%
Load regulation	Nominal input voltage, 20%~100% load	Vo	-	-	±5.0	%
Ripple & Noise	5%-100% load, 20MHz bandwidth	Vo	-	-	200	mVp-p
Note: The Ripple& Noise is tested by the Parallel-line method, please refer to the following test instruction.						
Dynamic response	Overshoot range	25%~50%~25%	-5.0	-	+5.0	%
	Recovery time	50%~75%~50%	-	-	5.0	mS
Minimum load	Single Output	0	-	-	%	
Temperature drift coefficient	-	-	-	±0.03	%/°C	
Turn-on delay time	Input 115VAC (full load)	-	-	2000	mS	
	Input 220VAC (full load)	-	-			
Power-off hold up time	Input 115VAC (full load)	-	10	-	mS	
	Input 220VAC (full load)	-	100	-		
Output start-up overshoot	Full input voltage range	≤10			%Vo	
Short circuit protection		Continuous, Self-recovery			Hiccup	
Over current protection	Input 220VAC	150%Io	-	220%Io	mA	
Over voltage protection	Output 3.3VDC	≤5.0				
	Output 5VDC	≤7.5			VDC	

	Output 12VDC	≤18
	Output 15VDC	≤20
	Output 24VDC	≤30

General Specifications						
Items	Test Conditions		Min.	Typ.	Max.	Unit
Switching frequency	-		-	65	-	KHz
Operating temperature	Refer to the temperature derating curve		-40	-	+75	°C
Storage temperature	-		-40	-	+85	
Soldering temperature	Wave-soldering		260±4°C, timing 5-10s			
	Manual-soldering		360±8°C, timing 4-7s			
Relative humidity	-		10	-	90	%RH
Isolation voltage	I/P-O/P	Test 1min, leakage current <5mA	4000	-	-	VAC
Insulation resistance	I/P-O/P	@DC500V	100	-	-	MΩ
MTBF	MIL-HDBK-217F@25°C		300	-	-	K hours
Safety Standards	EN 62368-1, IEC 61558-1					
Vibration	10-55Hz, 10G, 30Min, along X, Y, Z					
Safety class	-		CLASS II			
Weights & Dimensions	Part No.	Weight (Typ.)	Dimensions L x W x H			
	FA5-220SXXY2N4	30g	50.80X25.40X15.60 mm		2.000X1.000X0.614 inch	
	FA5-220SXXY2N4-T	50g	76.00X31.50X24.50 mm		2.992X1.240X0.965 inch	
	FA5-220SXXY2N4-TS	70g	76.00X31.50X29.00 mm		2.992X1.240X1.142 inch	

EMC Performance					
Items		Test Standards	Performance/Class		
EMC	EMI	CE	CISPR32/EN55032	CLASS B (with the Recommended EMC Circuit 1)	
		RE	CISPR32/EN55032	CLASS B (with the Recommended EMC Circuit 1)	
	EMS	RS	IEC/EN61000-4-3	10V/m Perf. Criteria A	
		CS	IEC/EN61000-4-6	10Vr.m.s Perf. Criteria A	
		ESD	IEC/EN61000-4-2	Contact ±8KV, Air ±15KV Perf. Criteria B	
		Surge Immunity	IEC/EN61000-4-5	Line to line ±1KV Perf. Criteria B	
				Line to line ±2KV Perf. Criteria B (with the Recommended EMC Circuit 1)	
		EFT	IEC/EN61000-4-4	±1KV Perf. Criteria B	
				±2KV Perf. Criteria B (with the Recommended EMC Circuit 1)	
		PFMF	IEC/EN61000-4-8	10A/m Perf. Criteria A	
Voltage dips & interruptions	IEC/EN61000-4-11	0%~70% Perf. Criteria B			

Product Characteristic Graphs

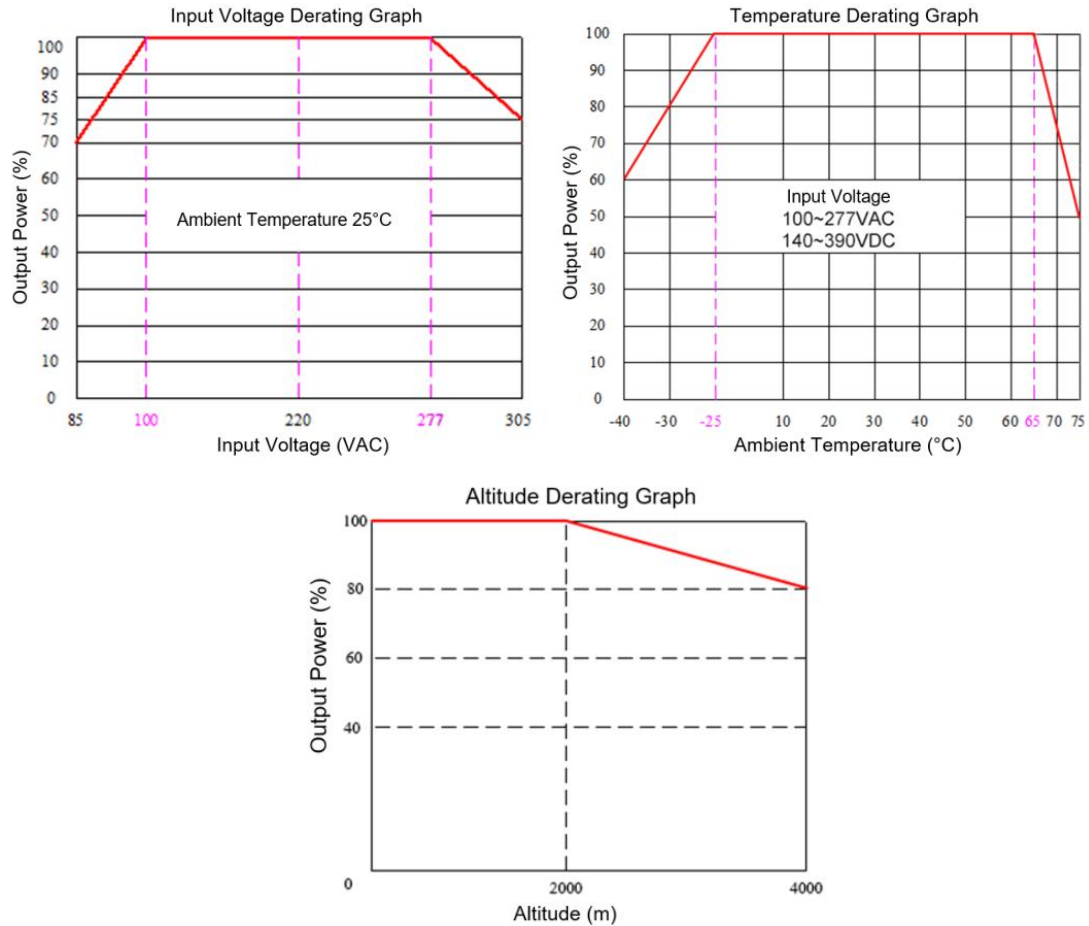

Note 1: Input voltage ranges from 85~100VAC/277~305VAC/120~140VDC/390~430VDC. Voltage derating must be applied based on the Input Voltage Derating Curve.

Note 2: This product is suitable for use in environments with natural convection cooling. For use in enclosed environments, please contact our company.

Recommended Circuits for Application

1. Recommended EMC circuit diagram

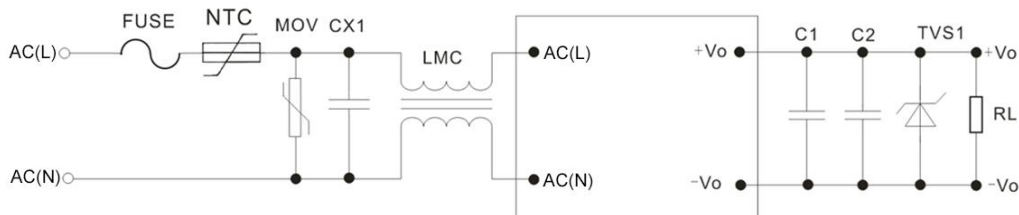

Figure 1

Component	Recommended Value	Device Name	Recommended Value
FUSE (Required)	2A/300VAC, Slow Blow	LMC1 Common Mode Choke	40mH/0.3A
MOV	14D561K/4500A	C1 Electrolytic Capacitor	10 μ F/50V
NTC	10D-11	C2 Ceramic Capacitor	0.1 μ F/50V
CX1 X capacitor	X2/104K/310VAC	TVS TVS Diode	See notes below

Note:

TVS1 is a Transient Voltage Suppressor (TVS) diode. The recommended models for different output voltages are as follows:

- 5V Output: SMBJ7.0A
- 9V Output: SMBJ12.0A
- 12V Output: SMBJ20A
- 15V Output: SMBJ20.0A
- 24V Output: SMBJ30.0A
- 48V Output: SMBJ64A

2. Recommended External Circuit for Ripple Reduction (FA5-220S3V3Y2N4 & FA5-220S05Y2N4)

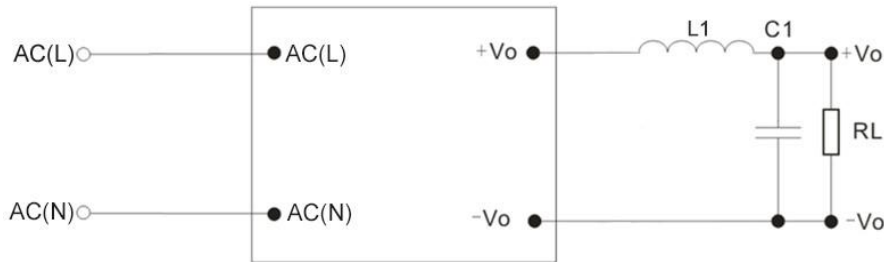
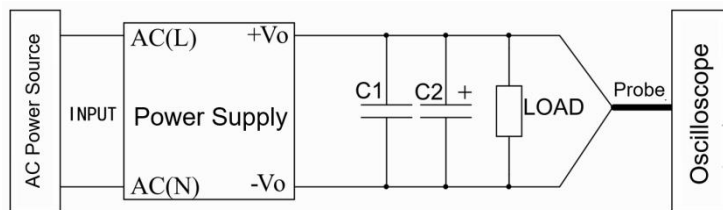

Figure 2

Device Name	Recommended Device Values
C1 Solid Capacitor	220μF/10V
L1 Rod-Type Inductor	2.2μH/2A

Ripple & Noise Test Instruction (Parallel-line Method, 20MHZ bandwidth)

Test Method:



1. Ripple & Noise Test Configuration:

Ripple and noise are measured using the parallel cable method. Set the oscilloscope to 20MHz bandwidth and Sample mode. Use a 100MHz bandwidth probe with the probe cap and ground clip removed. Connect a 0.1μF ceramic capacitor (C1) and a 10μF high-frequency, low-ESR electrolytic capacitor (C2) in parallel at the probe tip.

2. Test Setup Diagram Description:

Connect the input of the module to the power supply, and connect the output to the electronic load via a test jig. Use dedicated sampling wires to measure directly at the output terminals. Ensure that insulated power cables with an appropriate wire gauge are selected based on the actual output current.

Mechanical Dimensions

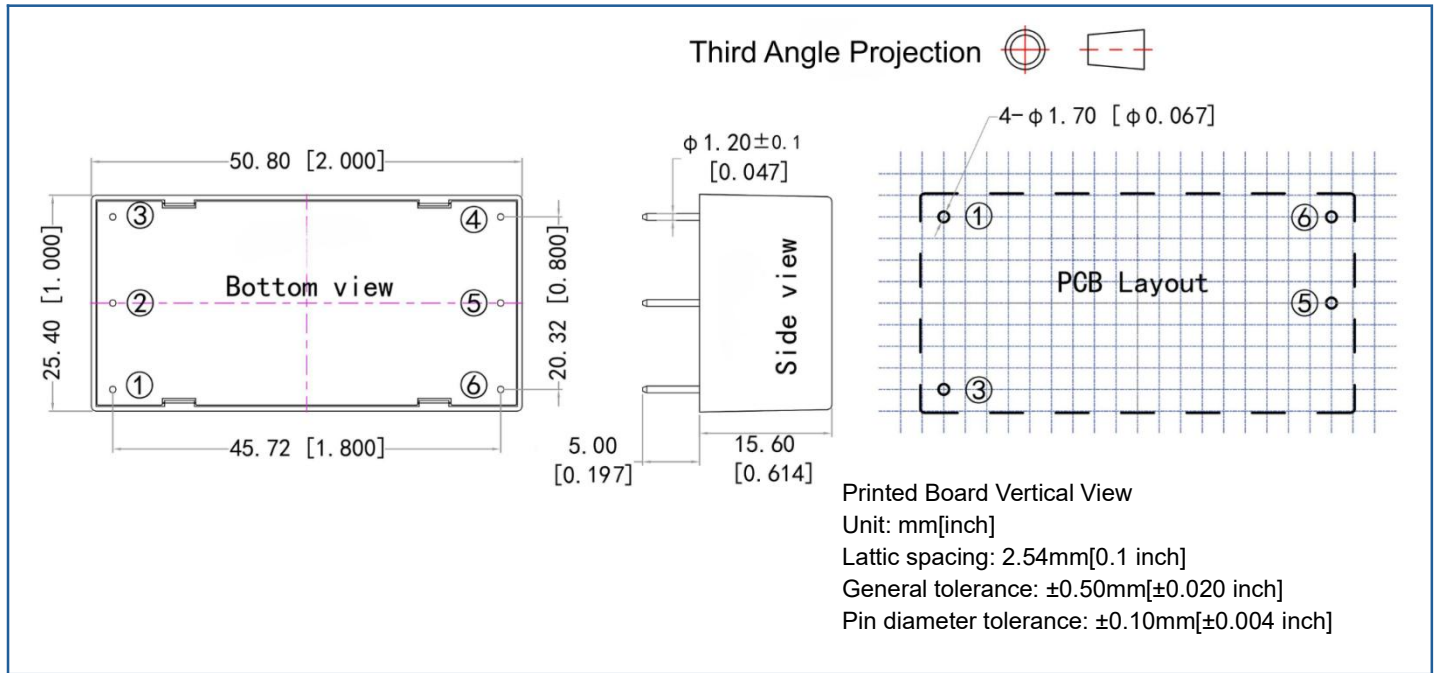

Pin-out Function Description

Pin No.	1	2	3	4	5	6
Symbol	AC(L)	NP	AC(N)	NP	-Vo	+Vo
Description	AC Line	No Pin	AC Neutral	No Pin	Negative Output	Positive Output

(-T) Mechanical Dimensions

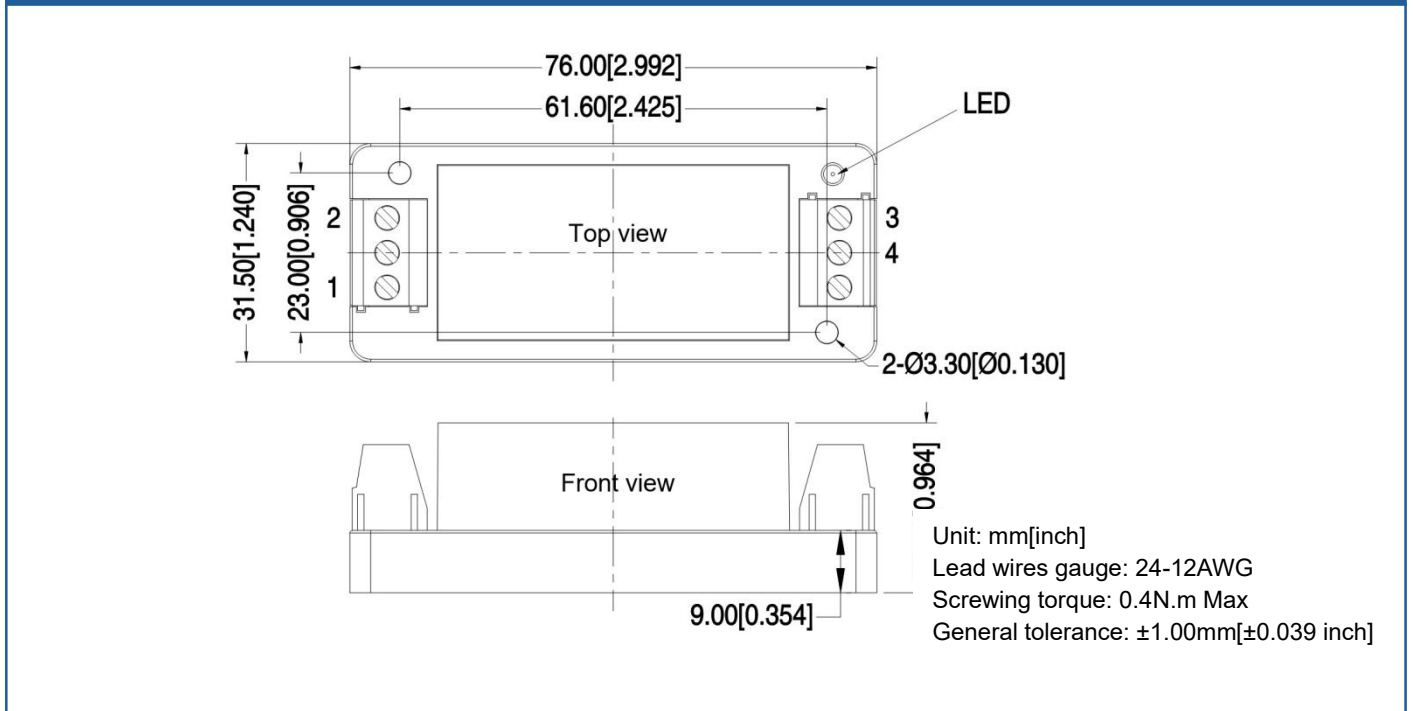

Terminal Function Description

Terminal No.	1	2	3	4
Symbol	AC(N)	AC(L)	+Vo	-Vo
Description	AC Neutral	AC Line	Positive Output	Negative Output

(-TS) Mechanical Dimensions

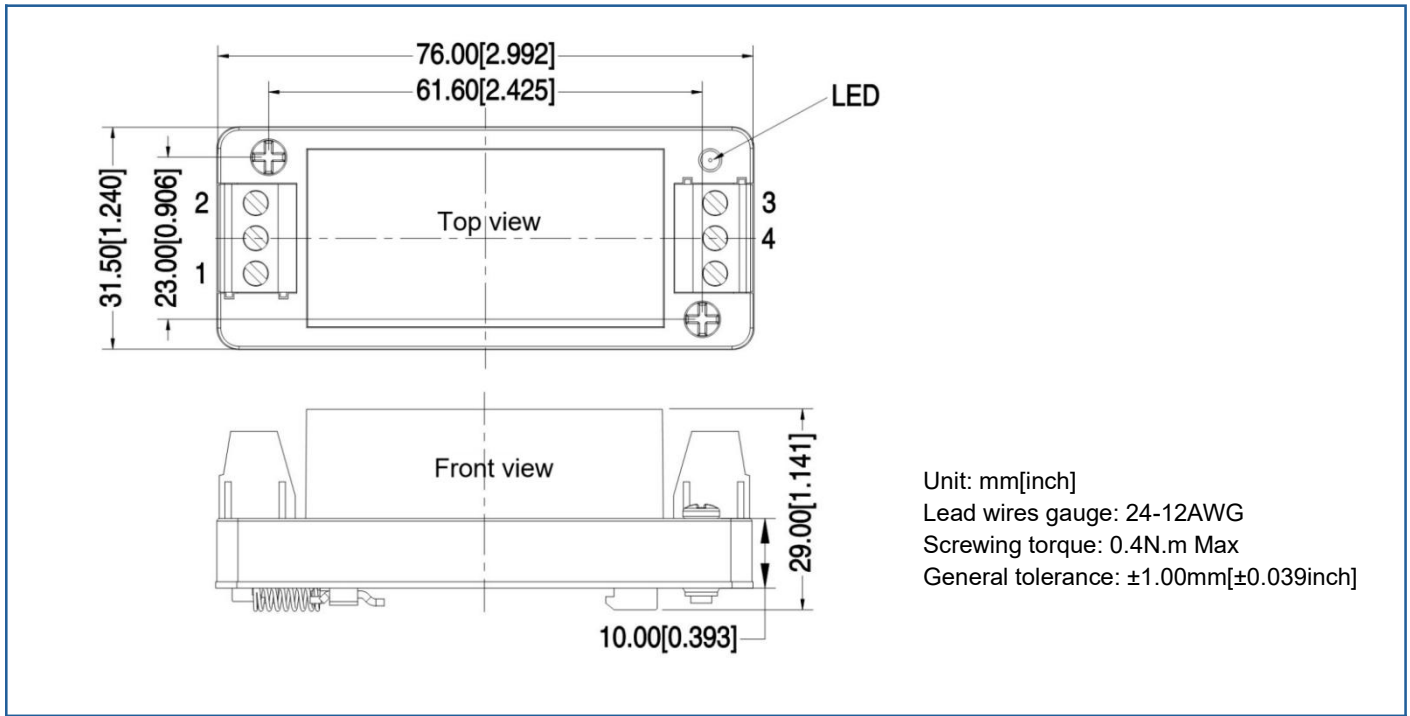

Unit: mm[inch]
 Lead wires gauge: 24-12AWG
 Screwing torque: 0.4N.m Max
 General tolerance: ±1.00mm[±0.039inch]

Terminal Function Description

Terminal No.	1	2	3	4
Symbol	AC(N)	AC(L)	+Vo	-Vo
Description	AC Neutral	AC Line	Positive Output	Negative Output

Application Notice:

1. The product must be operated within the specified parameters; otherwise, permanent damage may occur.
2. If the product operates below the minimum load requirement, we cannot guarantee that all performance specifications in this manual will be met.
3. If the product operates beyond its specified load range, we cannot guarantee that all performance specifications in this manual will be met.
4. Unless otherwise specified, all specifications are measured at Ta = 25° C, humidity < 75%, nominal input voltage, and rated output load (resistive load).
5. All testing methods for the specifications listed above are based on our corporate standards.
6. The specifications listed above apply to the standard models in this manual. Specifications for non-standard or customized models may vary. For specific details, please contact our technical support team.
7. Aipupower can offer customized power solutions to meet specific requirements.

Guangzhou Aipu Electron Technology Co., Ltd

Address: Building 4, HEDY Park, No.63, Punan Road, Huangpu Dist, Guangzhou, China

Tel: 86-20-84206763 Fax: 86-20-84206762 HOTLINE: 400-889-8821

E-mail: sales@aipu-elec.com Website: <https://www.aipupower.com>